

**Critical Environment Technologies
Canada Inc.**

www.critical-environment.com

**Installation Manual for
AST-IS18-M**

**Infrared CO₂ Modbus Transmitter
(0-4% volume range), IP65 Rated, Industrial
Enclosure, LCD Display & 2 Relays**



MANUAL REVISION-A, September 2017

**#145, 7391 VANTAGE WAY
DELTA, BC CANADA V4G 1M3
PH: 604-940-8741 TOLL FREE: 877-940-8741**

IMPORTANT NOTE

Read and understand this manual prior to using this instrument. Carefully read the warranty policy, service policy, notices, disclaimers and revisions on the following pages.

This product must be installed by a qualified electrician or factory trained technician and according to instructions indicated in this manual. This instrument should be inspected and calibrated regularly by a qualified and trained technician.

This instrument has not been designed to be intrinsically safe. For your safety, **do not** use it in classified hazardous areas (explosion-rated environments).

INSTRUMENT SERIAL NUMBER:

PURCHASE DATE:

PURCHASED FROM:

WARRANTY POLICY

Critical Environment Technologies Canada Inc. (CETCI), also referred to as the manufacturer, warrants this instrument, (excluding sensors, battery packs, batteries, pumps and filters) to be free from defects in materials and workmanship for a period of **two years from the date of purchase from our facility**. The sensors have a warranty period of **one year on a pro-rated basis from the date of purchase from our facility**. If the product should become defective within this warranty period, we will repair or replace it at our discretion.

The warranty status may be affected if the instrument has not been used and maintained as per the instructions in this manual or has been abused, damaged, or modified in any way. This instrument is only to be used for purposes stated herein. The manufacturer is not liable for auxiliary interfaced equipment or consequential damage.

Due to ongoing research, development, and product testing, the manufacturer reserves the right to change specifications without notice. The information contained herein is based on data considered accurate. However, no warranty is expressed or implied regarding the accuracy of this data.

All goods must be shipped to the manufacturer by prepaid freight. All returned goods must be pre-authorized by obtaining a Returned Merchandise Authorization (RMA) number. Contact the manufacturer for a number and procedures required for product transport.

SERVICE POLICY

CETCI maintains an instrument service facility at the factory. Some CETCI distributors / agents may also have repair facilities; however, CETCI assumes no liability for service performed by anyone other than CETCI personnel.

Repairs are warranted for 90 days after date of shipment (sensors have individual warranties).

Should your instrument require non-warranty repair, you may contact the distributor from whom it was purchased or you may contact CETCI directly.

Prior to shipping equipment to CETCI, contact our office for an Returned Merchandise Authorization (RMA) number. All returned goods must be accompanied with an RMA number.

If CETCI is to do the repair work, you may send the instrument, prepaid, to:

Attention: Service Department
Critical Environment Technologies Canada Inc.
Unit 145, 7391 Vantage Way
Delta, BC, V4G 1M3

Always include your RMA number, address, telephone number, contact name, shipping / billing information, and a description of the defect as you perceive it. You will be contacted with a cost estimate for expected repairs, prior to the performance of any service work.

For liability reasons, CETCI has a policy of performing all needed repairs to restore the instrument to full operating condition.

Pack the equipment well (in its original packing if possible), as we cannot be held responsible for any damage incurred during shipping to our facility.

COPYRIGHTS

This manual is subject to copyright protection; all rights are reserved. Under international and domestic copyright laws, this manual may not be copied or translated, in whole or in part, in any manner or format, without the written permission of CETCI.

All software which CETCI utilizes and / or distributes holds a proprietary interest and is also subject to copyright protection and all rights are reserved. No party may use or copy such software in any manner or format, except to the extent that CETCI grants them a license to do so. **IF SOFTWARE IS BEING LOADED ONTO MORE THAN ONE COMPUTER, EXTRA SOFTWARE LICENSES MUST BE PURCHASED.**

DISCLAIMER

Under no circumstances will CETCI be liable for any claims, losses or damages resulting from or arising out of the repair or modification of this equipment by a party other

than CETCI service technicians, or by operation or use of the equipment other than in accordance with the printed instructions contained within this manual or if the equipment has been improperly maintained or subjected to neglect or accident. Any of the foregoing will void the warranty.

Under most local electrical codes, low voltage wires cannot be run within the same conduit as line voltage wires. It is CETCI policy that all wiring of our products meet this requirement.

It is CETCI policy that all wiring be within properly grounded (earth or safety) conduit.

REVISIONS

This manual was written and published by CETCI. The manufacturer makes no warranty or representation, expressed or implied including any warranty of merchantability or fitness for purpose, with respect to this manual.

All information contained in this manual is believed to be true and accurate at the time of printing. However, as part of its continuing efforts to improve its products and their documentation, the manufacturer reserves the right to make changes at any time without notice. Revised copies of this manual can be obtained by contacting CETCI or visiting www.critical-environment.com

Should you detect any error or omission in this manual, please contact CETCI at the following address:

Critical Environment Technologies Canada Inc.
Unit 145, 7391 Vantage Way, Delta, BC, V4G 1M3, Canada
Toll Free: +1.877.940.8741
Telephone: +1.604.940.8741
Fax: +1.604.940.8745
Email: marketing@cetci.com
Website: www.critical-environment.com

In no event will CETCI, its officers or employees be liable for any direct, special, incidental or consequential damages resulting from any defect in any manual, even if advised of the possibility of such damages.

AST-IS18-M

The AST-IS18-M Infrared Carbon Dioxide (CO₂) sensor / transmitter measures the concentration of carbon dioxide indoors in 0-4% volume, for applications such as inside greenhouses. It offers Modbus® RS-485 output. 2 relays and an LCD display all housed in an industrial, IP65 rated, water tight, wall mount enclosure. The enclosure cover has a built-in rubber gasket and all other connections must be tight and sealed to prevent water intrusion. It is designed for connecting to Direct Digital Control (DDC)

ITEM LOCATORS

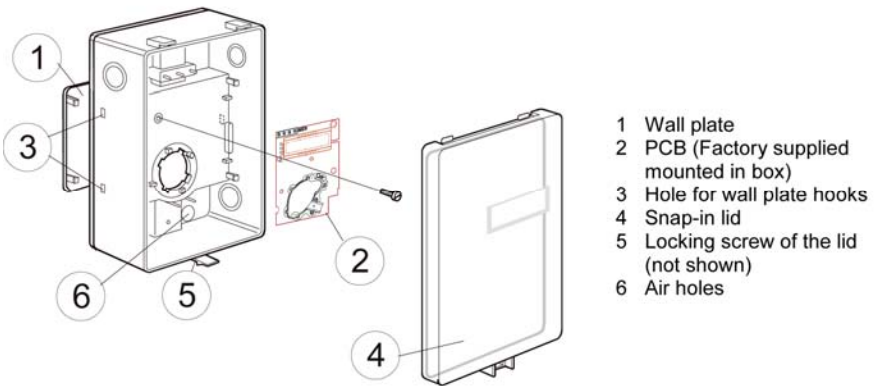

This product is in accordance with EMC 2004/108/EC, RoHS 2011/65/EU, 92/31/EEG including amendments by the CE-marking Directive 93/68/EEC.

This product fulfills the following demands:

EN 61000-4-2 Level 2, EN 61000-4-3 Level 2, EN 61000-4-4 Level 4, EN 61000-4-6, EN 61000-4-8 Level 4, EN 55022 Class B



KEY FEATURES:

- State of the art non-dispersive infrared (NDIR) technology to measure carbon dioxide gas
- Maintenance free in normal applications
- Membrane covered sample chamber for a stable, reliable and highly accurate carbon dioxide sensor
- Fully coated PCB together with a special filter equipped housing for resistance towards dust and humidity
- Modbus® RS-485 communication
- Two contact free relays (min load: 1mA/5V; rated load: 0.5A/125VAC, 1A/24VDC)

SPECIFICATIONS

Measurement Range	0 - 4% CO2
Power Supply	24 VDC or VAC, 50/60 Hz (half-wave rectifier input)
Power Consumption	<3 W average
Linear Output	n/a
Temperature Sensor Range	n/a
Accuracy	n/a
Operating Temperature	0oC to 50oC (32oF to 122oF)
Operating Humidity	0—95% RH non-condensing
Display	Yes
Enlosure Ratings	IP65 rated
Dimensions	177 x 85 x 38 mm
	7 x 3.35 x 1.5 inches
Alarm	No
Mute button	No
Relay Output	Min load: 1 mA / 5V Rated load: 0.5 A / 125 VAC, 1 A / 24 VDC
Mounting Type	Wall mount
Probe length	na
Communication	Modbus RS-485
Certifications	CE and EMC

WALL MOUNTING INSTRUCTIONS

The enclosure is delivered with the wall plate attached. The wall plate has to be removed before the sensor is mounted onto the wall. Unscrew the screw on the side of the box.

There are several mounting holes available to ensure a secure mounting location.

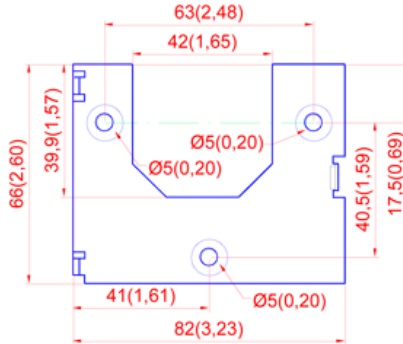

If cover must be removed for any reason, loosen single securing screw on bottom of enclosure, press tab to release cover and hinge upward to remove.

Normally the PCB should not be removed from the housing. If for some reason the PCB must be removed it must be handled carefully and protected from electrostatic discharge.

- 1) Electrical cable entry:** The box has a factory mounted cable entry bushing in dimension PG7, item-3 in drawing on previous page. Never feed more than one cable through each cable entry bushing, or else gas might leak through!
- 2) Screw the wall plate onto the wall:** The wall plate has several holes from which to choose the best location to secure the transmitter with screws. Drill holes for 3,5mm screws and put dowel into them. Dowels and screws 3,5 x 25mm are included in a plastic bag
- 3) The lid can be locked** with the screw at the bottom of the sensor box, item-5 on drawing on previous page.



If for some reason the PCB must be removed it must be handled carefully and protected from electrostatic discharge! Normally, removing the PCB is not required.

ELECTRICAL CONNECTIONS

The **power supply** has to be connected to G+ and G0. G0 is considered as system ground. The AST-IS18-M must have the same ground reference as the controller. Unless different transformers are used, special precautions need to be taken.

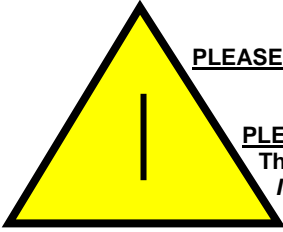



PLEASE NOTE! The *AST-IS18-M* RS485 GND *is not* galvanically separated from the *AST-IS18-M* power supply!

PLEASE NOTE!

The same ground reference has to be used for the *AST-IS18-M* unit and for the control system!

If possible, keep the sensor powered up after mounting.

Connection Terminal	Function	Electrical Data	Remarks
G+ 	Power (+)	24VAC/DC+ (+20%), 3W	2W without output load. <i>See note-1</i>
G0 	Power ground (-)	24VAC/DC -	
RS-485 Adapter			
A	Data line	Connects to next A data line in network	Do not reverse polarity (do not connect A to B)
B	Data line	Connects to next B data line in network	

NOTE 1: The ground terminal is used as negative power supply DC input or AC phase ground G0 (half wave rectifier). The RS485GND, protected by a PTC resistor, is the same as power ground G0 (permitting a "3-wire" configuration). A single transformer may be used for the entire system.

DIMENSIONS

Shown in mm (and inches)

Note: Enclosure is shown without wall plate brackets.

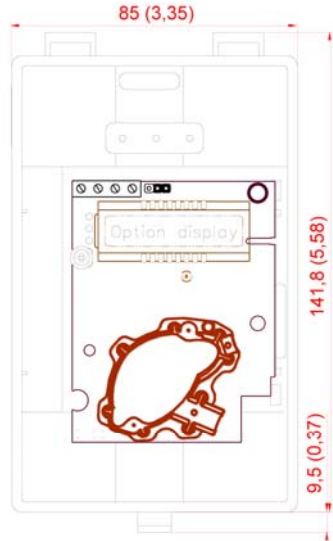
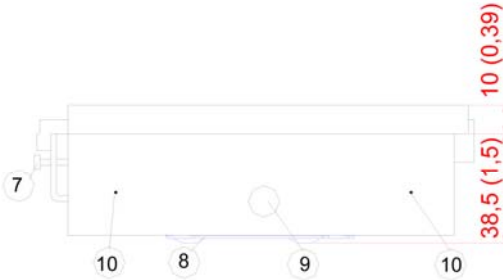

- 7 Lidlocking screw
- 8 Wall plate
- 9 Screw to hold the wall plate
- 10 Drill marking for cable entry bushings

WIRING TERMINAL STRIPS

The network adapter (indicated by the broken red line) is used to connect the AST-IS18-M to an RS-485 network. The green LED flashes every time the adapter answers calls from the network master. The adapter is placed on the UART connector with all five pins connected.

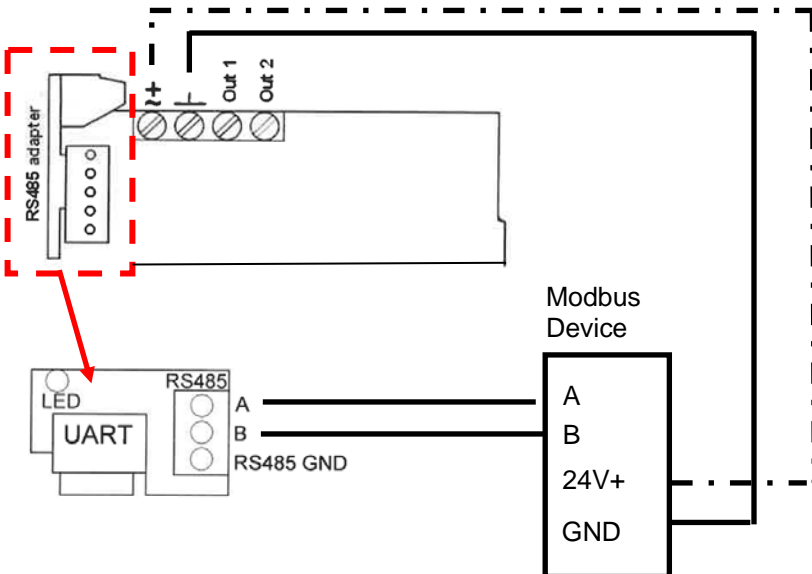

Critical Environment Technologies Canada Inc.

Unit 145, 7391 Vantage Way, Delta, BC, V4G 1M3, Canada

Toll Free: +1.877.940.8741

Tel: +1.604.940.8741

Fax: +1.604.940.8745

www.critical-environment.com

