

**Critical Environment Technologies
Canada Inc.**

YES Plus LGA

**Next Generation, Indoor Air Quality Monitor
& Information Recording Instrument**



OPERATION MANUAL

REV: A-2 FEB-1-2012

#145, 7391 Vantage Way Delta, BC V4G 1M3
Canada Phone: 604-940-8741 Fax: 604-940-8745
www.yestek.com

IMPORTANT NOTE

READ AND UNDERSTAND THIS MANUAL PRIOR TO USING THIS INSTRUMENT. CAREFULLY READ THE WARRANTY POLICY, SERVICE POLICY, NOTICES, DISCLAIMERS AND REVISIONS ON THE FOLLOWING PAGES.

THIS INSTRUMENT SHOULD BE INSPECTED AND CALIBRATED REGULARLY BY A QUALIFIED AND TRAINED TECHNICIAN.

THIS INSTRUMENT HAS NOT BEEN DESIGNED TO BE INTRINSICALLY SAFE. FOR YOUR SAFETY, **DO NOT** USE IT IN CLASSIFIED HAZARDOUS AREAS (EXPLOSION-RATED ENVIRONMENTS).

INSTRUMENT SERIAL NUMBER:

PURCHASE DATE:

PURCHASED FROM:

WARRANTY POLICY

CRITICAL ENVIRONMENT TECHNOLOGIES CANADA INC. (INCLUDING YES ENVIRONMENT TECHNOLOGIES INC.) WARRANTS THIS INSTRUMENT TO BE FREE FROM DEFECTS IN MATERIALS AND WORKMANSHIP FOR A PERIOD OF TWO YEARS, EXCLUDING SENSORS, FROM THE DATE OF PURCHASE BY THE ORIGINAL OWNER. THE SENSORS HAVE A WARRANTY PERIOD OF ONE YEAR FROM THE DATE OF PURCHASE. IF THE PRODUCT SHOULD BECOME DEFECTIVE WITHIN THIS WARRANTY PERIOD, WE WILL REPAIR OR REPLACE, IT AT OUR DISCRETION.

THE WARRANTY STATUS MAY BE AFFECTED IF THE INSTRUMENT HAS NOT BEEN USED AND MAINTAINED AS PER THE INSTRUCTIONS IN THIS MANUAL OR HAS BEEN ABUSED, DAMAGED OR MODIFIED IN ANY WAY. THIS INSTRUMENT IS ONLY TO BE USED FOR PURPOSES STATED HEREIN. THE MANUFACTURER IS NOT LIABLE FOR AUXILIARY INTERFACED EQUIPMENT OR CONSEQUENTIAL DAMAGE.

DUE TO ONGOING RESEARCH, DEVELOPMENT AND PRODUCT TESTING, THE MANUFACTURER RESERVES THE RIGHT TO CHANGE SPECIFICATIONS WITHOUT NOTICE. THE INFORMATION CONTAINED HEREIN IS BASED ON DATA CONSIDERED ACCURATE. HOWEVER, NO WARRANTY IS EXPRESSED OR IMPLIED REGARDING THE ACCURACY OF THIS DATA.

ALL GOODS MUST BE SHIPPED TO THE MANUFACTURER BY PREPAID FREIGHT. ALL RETURNED GOODS MUST BE PRE-AUTHORIZED BY OBTAINING A RETURN MERCHANDISE AUTHORIZATION (RMA) NUMBER. CONTACT THE MANUFACTURER FOR A NUMBER AND PROCEDURES REQUIRED FOR PRODUCT TRANSPORT.

SERVICE POLICY

CRITICAL ENVIRONMENT TECHNOLOGIES CANADA INC. (CETCI) MAINTAINS AN INSTRUMENT SERVICE FACILITY AT THE FACTORY. SOME CETCI DISTRIBUTORS / AGENTS MAY ALSO HAVE REPAIR FACILITIES, HOWEVER, CETCI ASSUMES NO LIABILITY FOR SERVICE PERFORMED BY ANYONE OTHER THAN CETCI PERSONNEL. REPAIRS ARE WARRANTED FOR 90 DAYS AFTER DATE OF SHIPMENT (SENSORS, PUMPS, FILTERS AND BATTERIES HAVE INDIVIDUAL WARRANTIES). SHOULD YOUR INSTRUMENT REQUIRE NON-WARRANTY REPAIR, YOU MAY CONTACT THE DISTRIBUTOR FROM WHOM IT WAS PURCHASED OR YOU MAY CONTACT CETCI DIRECTLY.

IF CETCI IS TO DO THE REPAIR WORK, CONTACT OUR OFFICE AND FIRST OBTAIN AN RMA NUMBER. YOU MAY SEND THE INSTRUMENT, BY PREPAID FREIGHT, TO CRITICAL ENVIRONMENT TECHNOLOGIES CANADA INC. , #145, 7391 VANTAGE WAY, DELTA, B.C. V4G 1M3, ATTENTION: SERVICE DEPARTMENT. ALWAYS INCLUDE YOUR RMA #, ADDRESS, TELEPHONE NUMBER, CONTACT NAME, SHIPPING / BILLING INFORMATION AND A DESCRIPTION OF THE PROBLEM AS YOU PERCEIVE IT. YOU WILL BE CONTACTED WITH A COST ESTIMATE FOR EXPECTED REPAIRS, PRIOR TO THE PERFORMANCE OF ANY SERVICE WORK. FOR LIABILITY REASONS, CETCI HAS A POLICY OF PERFORMING ALL NEEDED REPAIRS TO RESTORE THE INSTRUMENT TO FULL OPERATING CONDITION.

PRIOR TO SHIPPING EQUIPMENT TO CETCI, CONTACT OUR OFFICE FOR AN RMA # (RETURNED MERCHANDISE AUTHORIZATION). ALL RETURNED GOODS MUST BE ACCOMPANIED WITH AN RMA NUMBER.

PACK THE EQUIPMENT WELL (IN IT'S ORIGINAL PACKING IF POSSIBLE), AS WE CANNOT BE HELD RESPONSIBLE FOR ANY DAMAGE INCURRED DURING SHIPPING TO OUR FACILITY.

NOTICES

COPYRIGHTS: THIS MANUAL IS SUBJECT TO COPYRIGHT PROTECTION; ALL RIGHTS ARE RESERVED. UNDER INTERNATIONAL AND DOMESTIC COPYRIGHT LAWS, THIS MANUAL MAY NOT BE COPIED OR TRANSLATED, IN WHOLE OR IN PART, IN ANY MANNER OR FORMAT, WITHOUT THE WRITTEN PERMISSION OF CRITICAL ENVIRONMENT TECHNOLOGIES CANADA INC.

ALL SOFTWARE WHICH CETCI UTILIZES AND/OR DISTRIBUTES, HOLDS A PROPRIETARY INTEREST AND IS ALSO SUBJECT TO COPYRIGHT PROTECTION AND ALL RIGHTS ARE RESERVED. NO PARTY MAY USE OR COPY SUCH SOFTWARE IN ANY MANNER OR FORMAT, EXCEPT TO THE EXTENT THAT CETCI GRANTS THEM A LICENSE TO DO SO. IF THIS SOFTWARE IS BEING LOADED ONTO MORE THAN ONE COMPUTER, EXTRA SOFTWARE LICENSES MUST BE PURCHASED.

REFERENCE IMPORTANT NOTES ON PAGES:

DISCLAIMER

UNDER NO CIRCUMSTANCES WILL CRITICAL ENVIRONMENT TECHNOLOGIES CANADA INC. (CETCI) BE LIABLE FOR ANY CLAIMS, LOSSES OR DAMAGES RESULTING FROM OR ARISING OUT OF THE REPAIR OR MODIFICATION OF THIS EQUIPMENT BY A PARTY OTHER THAN CETCI SERVICE TECHNICIANS, OR BY OPERATION OR USE OF THE EQUIPMENT OTHER THAN IN ACCORDANCE WITH THE PRINTED INSTRUCTIONS CONTAINED WITHIN THIS MANUAL OR IF THE EQUIPMENT HAS BEEN IMPROPERLY MAINTAINED OR SUBJECTED TO NEGLIGENCE OR ACCIDENT. ANY OF THE FORGOING WILL VOID THE WARRANTY.

REVISIONS

THIS MANUAL WAS WRITTEN AND PUBLISHED BY CRITICAL ENVIRONMENT TECHNOLOGIES CANADA INC. (THE MANUFACTURER). THE MANUFACTURER MAKES NO WARRANTY OR REPRESENTATION, EXPRESSED OR IMPLIED INCLUDING ANY WARRANTY OF MERCHANTABILITY OR FITNESS FOR PURPOSE, WITH RESPECT TO THIS MANUAL. ALL INFORMATION CONTAINED IN THIS MANUAL IS BELIEVED TO BE TRUE AND ACCURATE AT THE TIME OF PRINTING. HOWEVER, AS PART OF IT'S CONTINUING EFFORTS TO IMPROVE IT'S PRODUCTS AND THEIR DOCUMENTATION, THE MANUFACTURER RESERVES THE RIGHT TO MAKE CHANGES AT ANY TIME WITHOUT NOTICE. REVISED COPIES OF THIS MANUAL CAN BE OBTAINED BY CONTACTING CRITICAL ENVIRONMENT TECHNOLOGIES CANADA INC. OR FROM OUR WEB SITE WWW.YESTEK.COM

SHOULD YOU DETECT ANY ERROR OR OMISSION IN THIS MANUAL, PLEASE CONTACT THE COMPANY AT THE FOLLOWING ADDRESS:

CRITICAL ENVIRONMENT TECHNOLOGIES CANADA INC.
UNIT 145, 7391 VANTAGE WAY
DELTA, BC V4G 1M3
CANADA

TOLL FREE: 1-877-940-8741
PHONE: 604-940-8741
FAX: 604-940-8745
E-MAIL: PORTABLES@CETCI.COM
WEBSITE: WWW.YESTEK.COM

IN NO EVENT WILL CRITICAL ENVIRONMENT TECHNOLOGIES CANADA INC., OR IT'S OFFICERS OR EMPLOYEES BE LIABLE FOR ANY DIRECT, SPECIAL, INCIDENTAL OR CONSEQUENTIAL DAMAGES RESULTING FROM ANY DEFECT IN ANY MANUAL, EVEN IF ADVISED OF THE POSSIBILITY OF SUCH DAMAGES.

PRINTED IN CANADA
Revision: A2-02-12

INDEX

<u>SECTION</u>	<u>DESCRIPTION</u>	<u>PAGE</u>
	IMPORTANT NOTE AND WARRANTY POLICY	3
	SERVICE POLICY AND NOTICES	4
	DISCLAIMER AND REVISIONS	5
	INDEX	6-7
	WELCOME	8
	YES PLUS LGA SHIPPING CHECK LIST	9
1.0	GENERAL	10
1.1	CONFIGURATIONS	10
2.0	SPECIFICATIONS	10-12
2.1	SENSOR CONFIGURATION NOTES	13
2.2	INSTRUMENT KEY FEATURES	13
3.0	DESCRIPTION PHOTO FRONT PANEL	14
3.1	DESCRIPTION PHOTO REAR PANEL	14
3.2	DESCRIPTION PHOTO INSTRUMENT INTERIOR	15
3.3	ENCLOSURE DIMENSIONS PHOTO	16
4.0	INSTRUMENT OPERATION	17
	BUTTON PRESSING	17
	SECURITY CODE	17
4.1	SWITCHING INSTRUMENT ON/OFF	17
4.2	BATTERY & "BATTERY WARNING"	18
4.3	MAIN MENU FUNCTIONS	18-19

INDEX

<u>SECTION</u>	<u>DESCRIPTION</u>	<u>PAGE</u>
5.0	MENU FUNCTION DETAILS	19-26
	CALIBRATE	19-20
	FREQUENCY	20
	SETTINGS	20-22
	SENSORS	20-21
	KEYPAD	21
	DISPLAY	21-22
	PUMP	22
	PASSCODE	22
	DEFAULT	22
	DATALOG	22-24
	DEFAULT	23
	SET UP	23
	ACTIVATE	23
	STOP LOG	24
	LOCATION	24
	MEM CARD	24
	ALARM	24-26
	INFO	26
	USB	26
6.0	CALIBRATION PROCEDURE	27-30
7.0	ADDING OR CHANGING PLUG & PLAY SENSORS	30-32
8.0	INFORMATION RECORDING OPERATION	32
9.0	MAINTENANCE	33
10.0	ACCESSORIES	33
	HAND-HELD PROBE	33
	HARD-SHELL CARRYING CASE	33

WELCOME

Thank you for purchasing our YES Plus LGA multi-sensor, air quality monitor and information recording instrument. The YES Plus LGA series of instruments are easy to use, portable, monitoring and information recording devices for monitoring trends that pertain to indoor air quality.

The YES Plus LGA is equipped with rear mounted temperature and relative humidity sensors to aid in verifying readings providing a comprehensive indication of air quality. Information readings are written to a plug-in SD flash card providing bullet-proof memory to protect your recorded information. The sample rate can be adjusted using the supplied software or through the instrument menu. The instrument may be hand-held or will easily stand on a flat surface.

The YES Plus LGA series of instruments are manufactured with plug-and-play, interchangeable sensor modules to allow for multiple gas testing. The specifications listed in this manual indicate a wide array of sensors to choose from. These sensors may be changed in the field and operated within minutes (accurate readings will require more time as each sensor type has different warm up / stabilization periods before they are able to perform to published specifications).

Calibration and repair is available at our manufacturing facility and through some of our authorized and trained distributors.

The YES Plus LGA can reliably record time-based information, which can be downloaded via the USB port located on the rear of the instrument or for faster downloading through the use of a USB card reader. Any computer capable of running Microsoft Windows 2000 or higher (with an available USB communications port) can accommodate the YES VIEWER terminal software.

If after reading through the manual, you have any questions, please do not hesitate to contact our service department for technical support.

YES Plus LGA SHIPPING CHECKLIST

This checklist ensures that you have received everything required to run your IAQ monitor / logger. If you do not receive any of the items listed below, contact the factory immediately:

- YES Plus LGA multi-gas monitor/logger
- AC wall adapter 12V @ 2.5 Amp
- Nickel-metal Hydride rechargeable battery pack (18 to 24 hours operation time)
- Calibration/probe fitting. Standard configuration only
- Operation manual
- YESVIEWER terminal data logging software package (option). Includes:
 - Software CD
 - USB Communications cable
 - SD flash card reader
- Other specified accessories (please refer to original sales order and the comments below):

Date: _____

Checked by: _____

1.0 GENERAL

The YES Plus LGA is a battery powered, portable indoor air quality monitor - information recording (data logging) instrument designed for intermittent or continuous operation. It's intended use is for indoor environments. A basic instrument includes a multi-line LCD alpha numeric display, audible alarm, rechargeable batteries, Temperature sensor, and operation manual.

The user can add up to thirteen (13) additional plug-and-play sensors (RH, electrochemical toxic gas and/or Oxygen, Infrared CO₂, PID or Catalytic combustible/flammable gas) internally for a maximum of thirteen internal sensors. Currently, a selection of up to thirty different sensors are available to choose from. Reference the list of available sensors on next page.

1.1 CONFIGURATIONS

YES Plus LGA is available in two configurations. The standard YES Plus LGA with internal sample pump or the Landfill Gas Analyzer version.

2.0 SPECIFICATIONS

Enclosure:	a) Dimensions: 10" Wide X 3.51" High X 7" Deep (254 mm Wide X 89 mm High X 178 mm Deep) b) Weight: 3.6 lbs. (1.7 kg)
Construction:	Rugged, ABS/Polycarbonate portable instrument enclosure UL94 rating
Power:	Standard: Rechargeable NiMH battery pack * Operational time on a full charge: 18 to 24 hours dependent upon the sensor array installed * Note: A "protection diode" in the circuit provides safety protection * Continuous: Plug-in, 12VDC, class-2, 2.5 Amp max. wall adapter. Adapter Input 100 to 240 VAC, 50 to 60 Hz / 700 mA
Visual:	Back-lit, multi-line LCD alphanumeric display 4-tactile push-buttons for user access
Monitoring Mode:	Internal, automatic sample pump for "Active" sampling of target environment
Circuit:	powerful microprocessor, user configurable
Operating Ranges:	Temperature: 5 to 50 degrees C (41 to 122 degrees F) Relative Humidity: 0 to 99% RH non-condensing

2.0 SPECIFICATIONS, CONT'D.....

SENSORS (PLUG & PLAY) AVAILABLE FOR YES Plus LGA

SENSOR	STANDARD RANGE	PART #
Carbon Dioxide (CO ₂)	0 - 5000 ppm	PNP-A+
Carbon Dioxide (CO ₂)	0 - 5.0% volume	PNP-B
Combustibles (flammables) infrared	0 - 5% volume CH ₄	PNP-B+
Carbon Dioxide (CO ₂)	0-100% volume	PNP-B1
Combustibles (flammables) infrared	0 - 100% volume	PNP-B2
Carbon Monoxide (CO)	0 - 50 ppm	PNP-C
Nitrogen Dioxide (NO ₂)	0 - 5.0 ppm	PNP-D
Nitric oxide (NO)	0 - 100 ppm	PNP-E
Oxygen (O ₂)	0 - 25.0% volume	PNP-F
Ozone (O ₃)	0 - 1.00 ppm	PNP-G
Ammonia (NH ₃)	0 - 50 ppm	PNP-H
Chlorine (Cl ₂)	0 - 5.0 ppm	PNP-I
Chlorine Dioxide (ClO ₂)	0 - 1.0 ppm	PNP-J
Hydrogen (H ₂)	0 - 1000 ppm	PNP-K
Hydrogen Sulphide (H ₂ S)	0 - 50 ppm	PNP-L
Hydrogen Chloride (HCl)	0 - 30 ppm	PNP-M
Hydrogen Cyanide (HCN)	0 - 100 ppm	PNP-N
Hydrogen Flouride (HF)	0 - 10 ppm	PNP-O
Sulphur Dioxide (SO ₂)	0 - 20 ppm	PNP-P
Formaldehyde (HCHO)	0 - 10 ppm	PNP-Q
Arsine (AsH ₃)	0 - 2.0 ppm	PNP-R
Flourine (F ₂)	0 - 2.0 ppm	PNP-S
Hydrazine (N ₂ H ₄)	0 - 1.0 ppm	PNP-T
Phosgene (COCl ₂)	0 - 1.0 ppm	PNP-U
Phosphine (PH ₃)	0 - 1.0 ppm	PNP-V
Silane (SiH ₄)	0 - 1.0 ppm	PNP-W
Combustibles (flammables)	0 - 100% LEL	PNP-X1
Total Volatile Organic Compounds (TVOC)	0 - 300 ppm	PNP-Y+
Total Volatile Organic Compounds (TVOC)	0 - 30 ppm	PNP-Z+

NOTE-1: Not all of the above sensors are available from stock. Delivery time for sensors ordered will vary depending on which sensors are ordered, how many are ordered and measurement range desired.

NOTE-2: Other measurement ranges are available for some sensors. Contact factory with desired range to confirm availability.

NOTE-3: Some of the these sensors must be calibrated with correlation gases because they are more readily available. If the customer wishes them to be calibrated with the exact target gas, extra charges will apply to acquire the specific gas if and when available. In these cases, customer will be required to take delivery of the special cylinder of span gas and dangerous goods and shipping costs will apply.

NOTE-4: Some of the above sensors have cross sensitivities to other gases (interfering gases). Please refer to the sensor specification chart before ordering a specific sensor if your application may have some of the interfering gases present.

NOTE-5: All sensors have an identifiable life span and must be replaced at the end of their usable life. Reference the following sections for more information: pages 28-30, section 7.0 and page-26, section-6.

2.1 SENSOR CONFIGURATION NOTES, IMPORTANT

It is important to note that although the YES Plus LGA will accommodate fifteen sensors and twelve (12) of those sensor locations are plug and play, there are sensor placement considerations.

Of the twelve plug and play sensor locations, eight are for electrochemical sensors. If the user selects an Oxygen (O₂) sensor or any other 2-electrode electrochemical sensor, it must be fitted to either sensor location 7 or 8. If the user selects a Nitric Oxide (NO) or any other sensor requiring electronic bias within the circuit, it must be fitted to sensor location 5 or 6. Sensor locations 1 to 8 can accommodate any other standard 3-electrode electrochemical sensor. Sensor locations 9 to 12 accommodate infrared, PID or catalytic sensors. Reference the photo drawing on page-32 for specific sensor locations.

2.2 INSTRUMENT KEY FEATURES

- * Comfortable to hold with handle
- * Flame rated ABS/polycarbonate enclosure
- * Displays up to six installed sensors at one time on backlit LCD, scrolls to display more
- * Multi-function, easy to use menu
- * Operates from nickel metal hydride (NiMH) rechargeable battery pack or continuously from the plug-in power adapter
- * Samples air with internal sample draw pump * Standard configuration
- * Accommodates electrochemical, catalytic, PID or infrared sensor types
- * Thirty different plug & play sensors available to choose from
- * Logs information and events to small SD flash card
- * USB data downloading and auxiliary up loading from remote probes
- * Windows XP, VISTA compatible

3.0 DESCRIPTION PHOTO OF FRONT PANEL

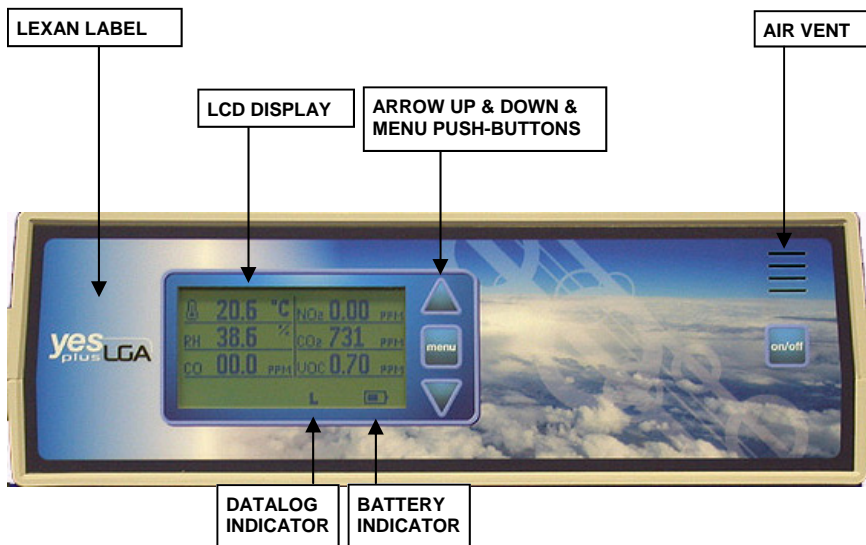

3.1 DESCRIPTION PHOTO REAR PANEL

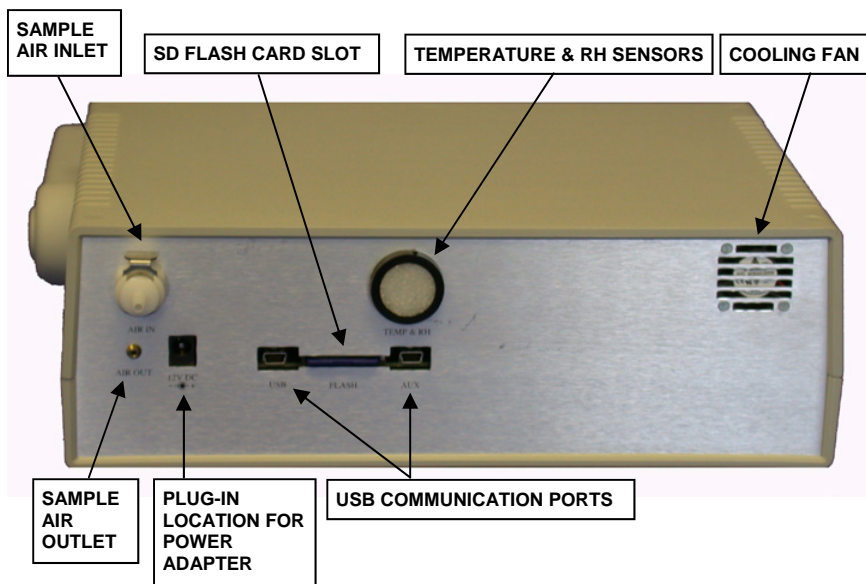

3.2 DESCRIPTION PHOTO INSTRUMENT INTERIOR

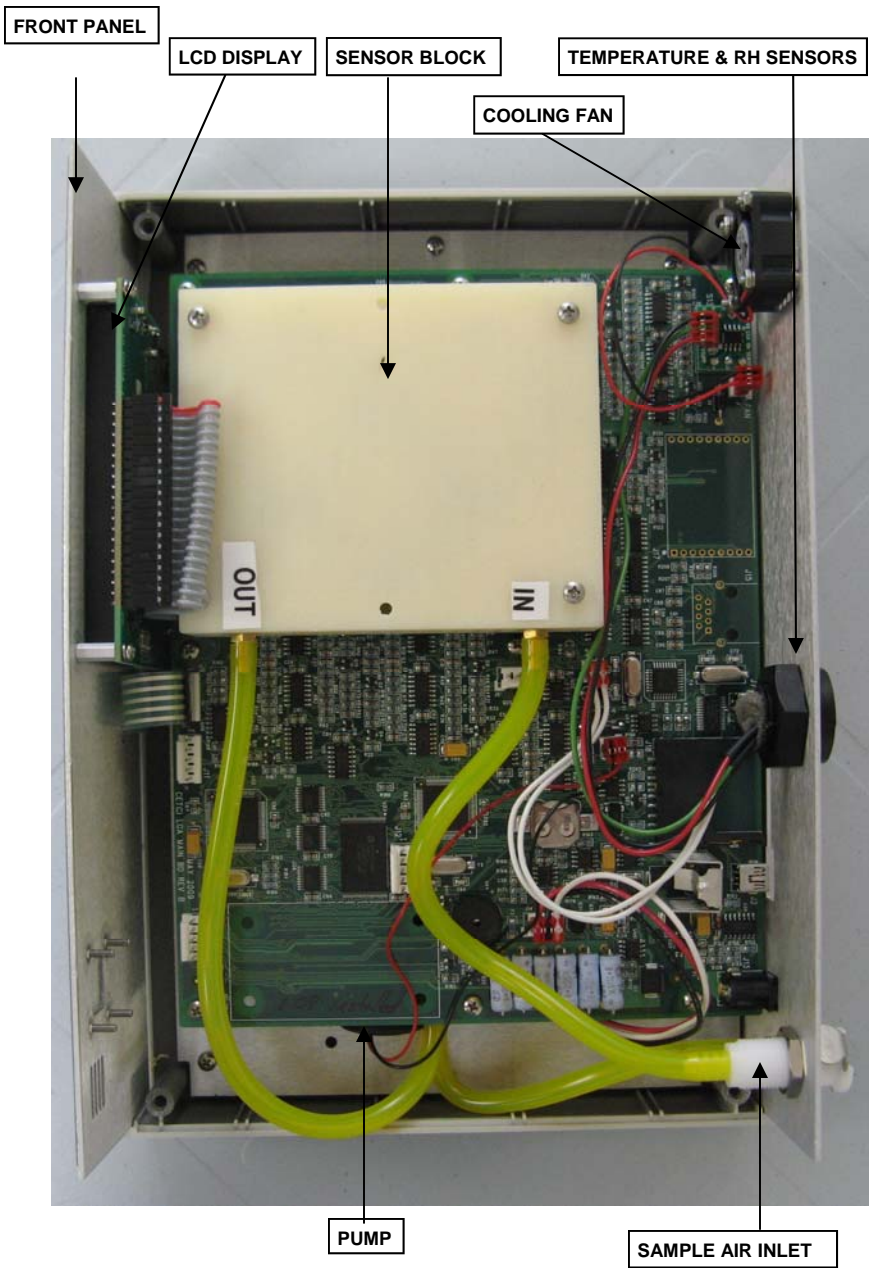

3.3 ENCLOSURE DIMENSIONS PHOTO

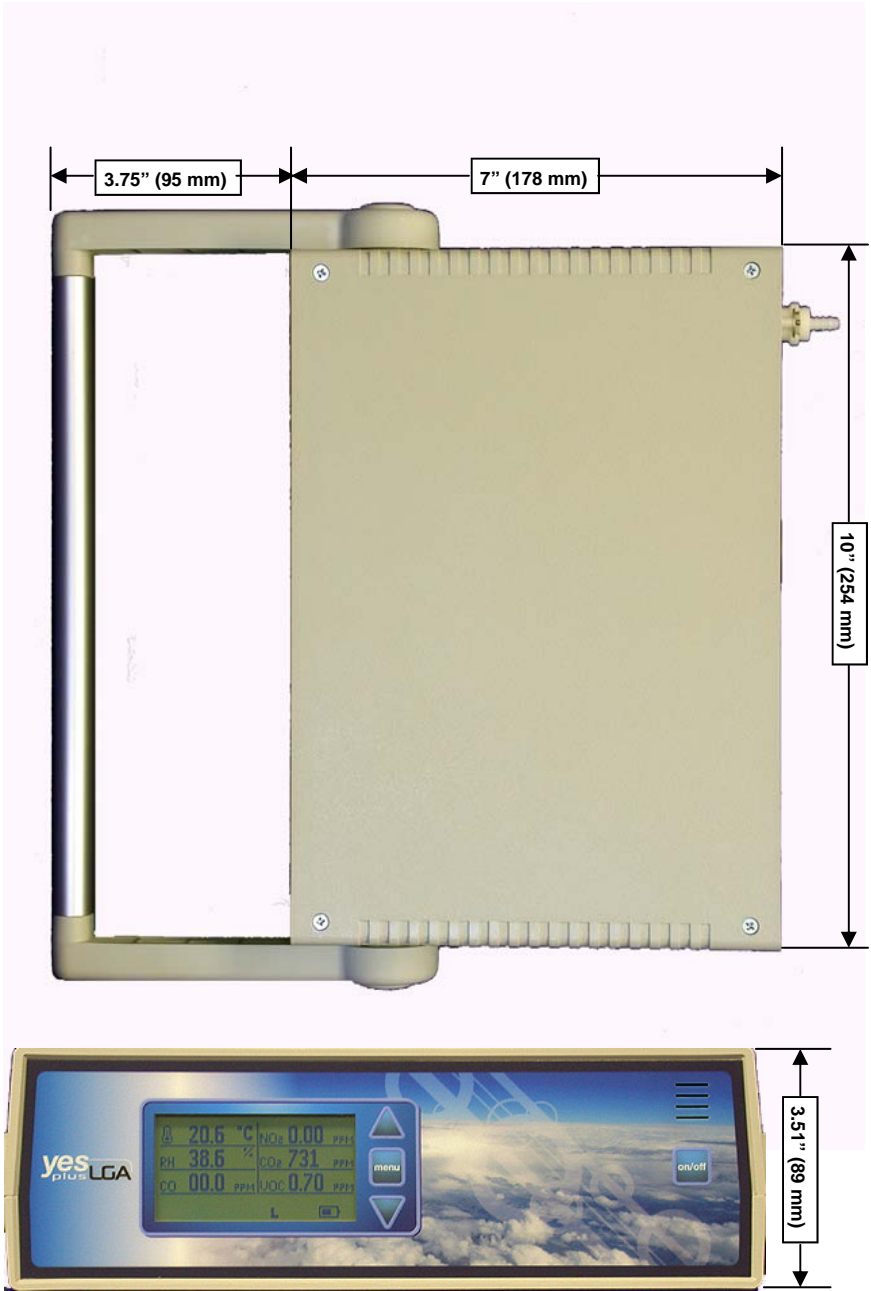

4.0 INSTRUMENT OPERATION

The YES Plus LGA has an extensive menu system allowing the user to access a wide range of features and functionality. All features and functions can be set to meet the user's specific requirements.

BUTTON PRESSING: The four tactile push-buttons on the front face of the instrument should be pressed firmly and slowly. They have been designed such that an accidental light touch does not register and change something the user may be working on.

SECURITY CODE: Some functions within the menu system are protected by a security code to prevent unauthorized or untrained personnel from accessing them and changing critical values within the instrument that might produce incorrect or unsafe readings. All YESAIR instruments are shipped from the factory with a generic security code of "1, 2, 3, 4". It is recommended the user change this to a code known only to authorized personnel.

4.1 SWITCHING INSTRUMENT ON / OFF

IMPORTANT NOTE: WHEN USING PUSH-BUTTONS ON FRONT OF INSTRUMENT ENCLOSURE, PRESS FIRMLY AND WATCH THE DISPLAY FOR MOVEMENT. A LIGHT FINGER PRESS WILL NOT ENGAGE THE DOMED CONTACT. THIS IS TO PREVENT ACCIDENTAL CHANGES TO MENU.

SWITCH ON: Press "ON/OFF" button down momentarily then release. The LCD will indicate "YES+LGA PORTABLE AIR QUALITY MONITOR", **FIRMWARE VERSION**, **CURRENT DATE**, **CURRENT TIME**, and finally "WARMING UP UNIT, PLEASE WAIT...". At the bottom of the display, a bar will fill in and indicate the percentage of warm-up completion to the right. A battery symbol will be indicated on the bottom right side of the display if the instrument is being operated from battery power.

After warm-up is completed, the display will automatically display the sensor type, real time reading and unit of measure for the first six sensors. If more than six sensors are installed, the display will automatically scroll to another page and display the balance of the installed sensor types, real time readings and unit of measure.

SWITCH OFF: Hold "ON/OFF" button down for four to six seconds then release. The multi-line LCD will indicate "Shutting monitor off".

NOTE-1: More accurate real-time readings will occur after the sensors have warmed up and stabilized a little longer.

NOTE-2: Warm-up can be skipped by holding the MENU button for 3-5 seconds

There are three more tactile push-buttons on the front panel of the instrument. "Arrow up", "Menu" and "Arrow Down". These buttons are used to access the instrument menu system for programming purposes.

IMPORTANT NOTE: Upon switching the YES Plus LGA on, the user will hear a low, steady buzzing tone. This is the sound of the new, powerful internal sample pump. The sound has been dampened internally but the sound of the pump will always be audible to a certain extent.

4.2 BATTERY & BATTERY WARNINGS

The YES Plus LGA operates from two different power sources. Rechargeable Nickel Metal Hydride (NiMH) sealed battery pack or plug-in wall adapter/battery charger. Reference page-10, section 2.0 for specifications. The YES Plus LGA is supplied with and configured for rechargeable batteries from the factory. **DO NOT ATTEMPT TO OPERATE THIS INSTRUMENT WITH ANY OTHER POWER SOURCE THAN WHAT WE PROVIDE. ANY DAMAGE RESULTING FROM SUCH AN ATTEMPT WILL VOID THE WARRANTY.**

CAUTIONS:

NOTE-1: Instrument will not charge the NiMH battery pack unless the instrument is switched off.

NOTE-2: Recharging a large battery pack such as what is installed in the YES Plus LGA can produce excess heat build up. When the adapter is plugged in to charge the instrument, the cooling fan located at the upper corner of the rear panel automatically switches on to draw any heat build up away. The fan automatically shuts off when the adapter is removed.

4.3 MAIN MENU FUNCTIONS

Pressing the MENU button after the main sensor array is displayed allows the user to enter the extensive menu system. The first menu display includes:

PREVIOUS
CALIBRATE
SETTINGS
DATALOG
ALARM
INFO
USB

NOTE: In all cases, use the ARROW DOWN or ARROW UP buttons to scroll through any displayed menu and use the MENU button to select any highlighted choices.

PREVIOUS: Allows the user to go back to the previous menu function. Pressing the **MENU** button repeatedly at "PREVIOUS" will step the user back one menu at a time until you finally reach the main sensor real-time display. Alternatively, hold down the **MENU** button for approximately 6 to 7 seconds and the LCD will jump back to the main, real-time sensor display.

CALIBRATE: Allows the user to enter the calibration section of the menu. This section is protected by a security code to prevent unauthorized people from attempting to calibrate the sensors. Reference page 28 for the calibration procedure. Enter the security code to proceed to the calibration function.

SETTINGS: This menu item provides the user with a number of instrument functions that can be set or modified to suit their personal use.

4.0 INSTRUMENT OPERATION

4.3 MAIN MENU FUNCTIONS, CONT'D.....

DATALOG: This menu item allows the user to set up the internal data logger to suit their specific application. This function can also be achieved with the instrument connected to a computer. Set up and programming through a pc is faster but the YES Plus LGA data logging function can be completely set up through the menu in the instrument.

ALARM: This menu item allows the user to set the alarm levels as well as which alarms are activated.

INFO: Provides the user with information on the instrument such as serial number assigned and date of manufacture. It also provides the user with information on the installed sensors such as sensor serial number, date code, and calibration date information.

USB: Allows the user to reset the USB chip if the YES Plus LGA will not communicate with YES Viewer software.

5.0 MENU FUNCTION DETAILS

CALIBRATE: Pressing the MENU button at this menu function puts the user into the calibration section of the menu. The LCD immediately indicates **ENTER SECURITY CODE**. The user must input a 4-digit security code to access the calibration menu. This prevents unauthorized users from tampering with the calibration settings. All YES Plus LGA instruments are shipped from the factory with a generic security code setting of "1234". The user can easily change this code setting for extra security. Reference page-22 of this manual.

NOTE: If the wrong security code has been entered, the display indicates **INVALID SECURITY CODE ENTERED** and the display flips back to the menu list.

The calibration menu provides the user with two main functions to calibrate all sensors, SPAN and ZERO. Both of these functions are required as part of the regular instrument maintenance to achieve "best performance" from the sensors. **Zero function must be performed before the span function.**

PID sensors for TVOCs (Total Volatile Organic Compounds) should be calibrated *every three months* for best performance if being used in dirty or semi-dirty environments. This sensor measures the "total" response from all VOCs in the target area and cannot identify individual gases or chemicals.

Infrared CO2 sensors should be calibrated *yearly* for best performance.

Electrochemical, toxic gas sensors should be calibrated *every six months* for best performance.

Catalytic, combustible gas sensors should be calibrated *every six months* for best performance.

5.0 MENU FUNCTION DETAILS

CALIBRATE, CONT'D.....

Both zero and span functions are automated. Before span adjusting the sensor, the user must first tell the YES Plus LGA what concentration of span gas is being used to span each sensor. This does not apply to temperature, RH or Oxygen sensors. Temperature and RH sensors must be calibrated using a controlled environment such as a chamber. With Oxygen sensors, it is assumed you will use the environment around you because it contains approximately 20.9% O₂. After that, push the menu button over the zero or span selection and follow the instructions on the LCD.

NOTE: For more information on calibration function, see calibration section 6.0, page 27 of this manual.

CALIBRATION FREQUENCY: The frequency of calibration maintenance to expect best performance from installed sensors. Temperature and Relative humidity sensors should be calibrated once per year. Reference bottom of page-21 for details on other sensor types.

SETTINGS: This menu item provides the user with the ability to configure much of the instrument functionality to suit their specific needs. Use the **ARROW DOWN** button to scroll to "SETTINGS" then push the **MENU** button to enter this menu and view the listed functions. Use the **ARROW DOWN** button to scroll to the function you wish to change and press the **MENU** button.

The functions available for modification are:

PREVIOUS
SENSORS
KEYPAD
DISPLAY
PUMP
PASS CODE
DEFAULT

SENSORS: This menu lists only the installed sensors that provide the user with the ability to adjust them from the menu. The choices are:

TEMP (always displayed)
RH
VOC (TVOCs)

Note: Only displayed if the RH and / or TVOC sensor is actually installed in the instrument.

TEMP: The options available are:

DEGREES C
DEGREES F
ADJUST

5.0 MENU FUNCTION DETAILS, CONT'D.....

SETTINGS, SENSORS, CONT'D.....

This menu item allows the user to change the temperature unit from degrees C to degrees F or visa versa. The second function allows the user to adjust the temperature value slightly to align it with another device. The third function allows the user to adjust the RH value slightly to align with another device. The choice is -1% or +1% RH.

Temperature adjust: This menu allows the user to “tweak” the displayed temperature value slightly (+/-1 degree C or +/- 2 degrees F). This function can only be used once to prevent excessive adjustment of temperature sensor without the use of a calibration chamber. Using the **ARROW DOWN** button, scroll to “**ADJUST**” and press the **MENU** button. The LCD will ask the user to input the desired numeric value. Once the last digit has been entered, the new temperature value will be automatically saved.

RH adjust: Use the **ARROW DOWN** button to scroll to the desired choice and push the **MENU** button. The choices are “**NONE**”, “**-1%**” or “**+1%**”.

VOC: This menu allows the user to switch the units of measure for the PID sensor only. The choices are: “**PPM**” or “**mg/m³**”. Using the **ARROW DOWN** button, scroll down to the desired unit of measure and push the **MENU** button to accept.

Once the user makes the desired changes as indicated above, push the “**MENU**” button, and the display will indicate “**VALUE HAS BEEN SAVED**”.

KEYPAD: This menu item allows the user to leave the keypad operational for anyone using the instrument or lock it so the settings cannot be changed by anyone. A lock symbol appears at the bottom of the LCD display to indicate the keypad lock has been engaged. Anyone trying to use the keypad will encounter a display requesting a four digit security code. The selections are “**NORMAL**” or “**LOCKED**”. The instrument is supplied with a generic security code for all lockable functions. It is “1,2,3,4”. Using the **ARROW DOWN** button, scroll down to the desired selection and press the **MENU** button to accept.

DISPLAY: The menu item provides the user with four settings that can be adjusted for the LCD, alpha-numeric, digital display. “**BACKLIGHT**”, “**NORMAL**”, “**BLANK**”, “**CONTRAST**”.

BACKLIGHT: This menu item allows the user to set the LCD display backlight to **ON** or **OFF**. Switching it off saves on battery power. Use the **ARROW DOWN** button or **ARROW UP** button to scroll to the desired setting (ON or OFF) and press the **MENU** button to make the change. Once the backlight has been switched “ON” through the menu, it will remain on for about 30-seconds. After that, the user can then push any button momentarily to activate the backlight for short periods of time. The backlight will remain on for 30-seconds with each activation from an arrow button then automatically turn off to save battery power.

5.0 MENU FUNCTION DETAILS, CONT'D.....

SETTINGS, DISPLAY, CONT'D.....

NORMAL: This menu item sets the display to the normal view of all installed sensors and their real time gas values. *Example:* If a user has blanked the LCD display or locked the keypad to prevent tampering, the "normal" function resets everything.

BLANK: This menu item allows the user to "blank" the LCD display so nobody can view the real time readings. This does not affect the data logging function at all. Using the **ARROW DOWN** button, scroll to the desired setting and push the **MENU** button to accept. The LCD goes completely blank. To view the LCD display again, push the **MENU** button and you will be required to enter the security code.

CONTRAST: This menu item allows the user to adjust the contrast of the LCD display. There are seven settings available and they are listed as: "**ONE, TWO, THREE, FOUR, FIVE, SIX, SEVEN**". Using the **ARROW DOWN** button, scroll down to the desired value and push the **MENU** button to accept.

PUMP: This menu item allows the user to select "**REG FLOW**" (regular flow) or "**HIGH FLOW**" for the pump. Regular flow sets the pump flow rate to approximately 0.5 LPM default. High flow increases the flow rate and should be used for the LGA (Landfill Gas Analyzer) instrument version. The higher flow rate helps to overcome the resistance of the hose and probe to maintain at least 0.5 LPM flow into the instrument. Using the **ARROW DOWN** button, scroll to the desired setting and push the **MENU** button to accept.

PASSCODE: This menu item allows the user to set a security pass code to prevent other people from changing the instrument settings. Pressing the **MENU** button at this option takes the user to the pass code set up screen. The user is required to enter the existing pass code first. Use the **ARROW UP** or **ARROW DOWN** buttons to input the existing pass code then push the **MENU** button. The display then indicates it is ready for a new pass code to be entered. Use the **ARROW UP** or **ARROW DOWN** buttons to set the desired numbers for a pass code. Pressing the **MENU** button at this point saves the new pass code. With the display indicating "**NEW PASS CODE HAS BEEN SAVED**".

DEFAULT: This menu item allows the user to quickly set up the instrument operating parameters. Pressing the **MENU** button at this menu function saves the default settings and the following message appears on the LCD: "**DEFAULT SET UP HAS BEEN APPLIED**".

DATALOG: This menu item allows the user to set up the information gathering (data logging) function that instructs the microprocessor what and how to write information to the flash memory card. The selections are: "**DEFAULT**", "**SET UP**", "**ACTIVATE**", "**STOP LOG**", "**LOCATION**", "**MEM CARD**".

5.0 MENU FUNCTION DETAILS, CONT'D.....

DATALOG, CONT'D.....

DEFAULT: This menu item provides the end user with a quick set up option for the data logging function. It sets up basic parameters for the information gathering function. The end user can still enter other menus to manually set up or change all parameters of the information gathering if desired for customizing it to their application. The LCD indicates **"DEFAULT SETUP HAS BEEN SAVED"**

DEFAULT SETUP: 1 min sample rate, Start logging on startup, End logging when file full, Location = NONE

SET UP: This menu item allows the user to select the sampling rate. Eight sampling rates are available to choose between, from once every 10-seconds to once every 30-minutes.

Sampling rates available:

10-secs, 30-secs, 1-min, 2-min, 5-min, 15-min, 30-min. After the sampling rate has been selected, the logger START method must be selected: "STARTUP" or "SET TIME".

STARTUP: Logging will start when the YESAIR is turned on and **ACTIVATE** has been selected from the **DATALOG** menu

SET TIME: User can set the time and date to start logging

After the **START** method has been selected the END method must be selected: "**FILE FULL**", "**FIXED**", or "**SET TIME**"

FILE FULL: Logging will stop when the flash card memory is full

FIXED: User selects how many samples to take before logging is stopped.

SET TIME: User can set the time and date to stop logging.

After the END method has been selected, the logging location must be selected. The selections available in the "LOC" (location) menu are:

NONE
SETUP
<EMPTY>
<EMPTY>
<EMPTY>
<EMPTY>
<EMPTY>
<EMPTY>

Choosing NONE will not set a location for logging. The user can customize this list as described on page 25.

ACTIVATE: This menu item allows the user to enable the data log (information recording) session. Press the **MENU** button at this item and the LCD indicates "**DATA LOG HAS BEEN ENABLED**"

5.0 MENU FUNCTION DETAILS, CONT'D.....

DATALOG, CONT'D.....

NOTE-1: Once the data logger has been set up, it will not start until “**ACTIVATE**” has been selected from the **DATALOG** menu.

NOTE-2: If the user experiences an error message “**MEMORY CARD CORRUPT**”, the flash card must be formatted. Reference information below under “**FORMAT**”..

NOTE-3: If memory card is not installed before “activate” is selected, the user will experience an error message “**PLEASE INSTALL MEMORY CARD**”. The display will then flip back to the data log menu, awaiting further instructions.

STOP LOG: This menu item allows the user to turn off the data log session. Press the **MENU** button at this item and the LCD indicates “**DATA LOG HAS BEEN STOPPED**”.

LOCATION: This menu item allows the user to enter names or identifiers (alpha/numeric) for up to six locations for logging purposes. Names are limited to eight characters. Example:

NONE
SETUP
KOREA (EXAMPLE)

MEM CARD: This menu function provides the user with information about the flash card and a function to format a new card. The selections are:

INFO
FORMAT

INFO: This menu function indicates the size of the flash card memory and the number of CSV files stored, if any.

FORMAT: This menu function is used to format all new flash cards. Any flash card provided by the factory has already been formatted. This format function is used to format new flash cards, erase flash cards, and reset flash cards if the memory is corrupt. Use pc to format any card when required and select **ONLY** “FAT-32” file system to format.

ALARM: This menu item allows the user to set up alarm set points that would activate the audible alarm. The menu choices are:

ALARM
SET ALARM

ALARM: The menu choices at this point are:

OFF
ALL
NEXT...
CO
CO2

5.0 MENU FUNCTION DETAILS, CONT'D.....

ALARM, CONT'D.....

NOTE: Only installed sensors show on this menu, eg. CO, CO2, etc. This menu will only display temperature and RH sensors if an alarm point has been set for them. Go to "SET ALARM" to reference setting alarm set points.

OFF: This menu item removes all asterisks in front of all sensors listed (installed) indicating they have been de-selected and will not be included in the alarm set list. Press the MENU button at this menu item and the LCD indicates "**ALARM SET UP HAS BEEN SAVED**". The display then goes back to the alarm menu screen.

ALL: This menu item puts an asterisk in front of all sensors listed (installed) indicating they have been selected to have an alarm set point. Press the **MENU** button at this menu item and the LCD indicates "**ALARM SET UP HAS BEEN SAVED**". The display then goes back to the alarm menu screen.

NEXT: Select next after you have highlighted only the sensors you want to have alarm set points for. Press the **MENU** button at this menu item and the LCD indicates "**ALARM SET UP HAS BEEN SAVED**". The LCD then goes back to the alarm menu.

TEMP: This menu item puts an asterisk in front of the temperature sensor (installed) indicating it has been selected to have an alarm set point.

HUMIDITY: This menu item puts an asterisk in front of the humidity sensor (installed) indicating it has been selected to have an alarm set point.

CO: This menu item puts an asterisk in front of the CO sensor (installed) indicating it has been selected to have an alarm set point

CO2: This menu item puts an asterisk in front of the CO2 sensor (installed) indicating it has been selected to have an alarm set point.

NOTE: Other sensors may be indicated here. Only installed sensors will be on this list. Pressing the MENU button at any of the sensors listed, puts an asterisk in front of the gas name, indicating it has been selected to activate the audible alarm if real-time gas values are above preset alarm levels.

SET ALARM: This menu item allows the user to enter an alarm set point for any installed sensor. The user must first enter a four digit security code. Use the **UP ARROW** or **DOWN ARROW** and **MENU** buttons to enter the desired numbers of the security code. When finished push the MENU button and the LCD will accept the code if it was entered correctly and display the list of installed sensors

Using the **ARROW DOWN** button, scroll down to the first sensor that you wish you enter an alarm set point for then push the **MENU** button. The display will indicate "**ENTER ALARM VALUE**". Use the **ARROW UP** and/or **ARROW DOWN** buttons to enter the desired numbers then press the **MENU** button to accept the new value. The LCD will indicate "**NEW ALARM VALUE ENTERED**" and go back to the list of installed sensors.

5.0 MENU FUNCTION DETAILS, CONT'D.....

ALARM, CONT'D.....

Once again, use the **ARROW DOWN** button to scroll down to the next sensor that is to have an alarm set point and repeat the procedure. Each time the **MENU** button is pressed to accept the new alarm set point, the LCD will go back to the list of sensors and the default cursor position is "**PREVIOUS**". When finished, press the **MENU** button at "**PREVIOUS**" and the alarm menu will be displayed.

INFO: This menu item provides the user with information about the instrument. The choices are for the instrument and installed sensors with serial numbers (does not include temperature and RH sensors as they do not have serial numbers). Example of choices are:

MONITOR
CO
CO2

MONITOR: LCD indicates instrument serial number and date of manufacture

CO: LCD indicates sensor serial number, sensor date code, and calibration information: span and zero dates

CO2: LCD indicates sensor serial number, sensor date code, and calibration information: span and zero dates

To access this information, scroll down to the desired sensor choice and using the **ARROW DOWN** button and press the **MENU** button. Once the information has been viewed, press the MENU button to return to the previous menu.

USB: This menu item allows the user to reset the USB chip if any problems are experienced while trying to communicate with YES Viewer software. After selecting **RESET** from this menu, the user will receive the message "**USB HAS BEEN RESET**".

NOTE: If you remove the USB cable before shutting down the YES Viewer program, the YES Plus LGA may continue to display "PC Mode". Press and hold the MENU button to clear this and return to normal measurement mode.

6.0 CALIBRATION PROCEDURE

This section details the calibration procedure and is an extension of the description from pages 19 to 21 of this manual.

NOTE: Calibration should always be performed by a trained and experienced technician. Temperature and Relative Humidity sensors must be calibrated using a special chamber and therefore field calibration is not permitted. Only gas sensors can be field calibrated.

Equipment Required & Cautions:

- 1) Always ensure batteries are fully charged before starting calibration procedure. This is especially important when calibrating sensors that are more “current hungry” such as infrared, combustible and PID for TVOCs.
- 2) Allow a twenty (20) minute warm up period before attempting calibration of any gas sensors. This allows all sensors time to fully warm up and stabilize and produces the most accurate results for calibration.
- 3) Always perform both zero (null) and span functions on all sensors. Zero function involves flowing 100% Nitrogen into the inlet port of the instrument.
- 4) Cylinders of Nitrogen and appropriate span gases are required for calibration. Ensure the cylinder regulator has a minimum flow rate of approximately 0.7 LPM to a maximum of 1.0 LPM. The pump inside the YES Plus LGA must not be “drawn down” because of a low flow rate from a cylinder regulator. The result will be inaccurate calibration values. Span gas values should preferably be approximately 40% to 60% of the installed sensor measurement ranges. Always remove cylinder regulators from air and gas cylinders before storing.

Calibration can be achieved from the instrument keypad menu or through the pc information gathering (data logging) software. The following procedure deals only with calibration procedure through the instrument keypad menu. The procedure to achieve calibration from the pc software can be found in the separate software manual.

PROCEDURE:

ZERO:

Press the **MENU** button on the instrument to enter the main menu. Using the **ARROW DOWN** button scroll down to “**CALIBRATE**” and press the **MENU** button. The LCD will indicate “**(CODE) ENTER SECURITY CODE**”. The calibration function is security code protected to prevent unauthorized personnel or personnel that have not been trained, from performing this important function.

Enter the security code correctly and the LCD indicates “**CAL**” and the next menu selections “**PREVIOUS**”, “**SPAN**” “**ZERO**”.

6.0 CALIBRATION PROCEDURE, CONT'D.....

PROCEDURE, ZERO CONT'D.....

NOTE: If incorrect code is input the LCD INDICATES “INVALID SECURITY CODE ENTERED” and the user is taken back to the basic menu.

Use the **ARROW DOWN** button to scroll down to the desired function and press the **MENU** button to select it. The LCD then indicates “PREVIOUS”, “ALL” and lists all installed sensors. Use the **ARROW DOWN** button to scroll to the desired sensor then push the **MENU** button to select. The LCD then indicates “ZERO” and “APPLY GAS NOW”. A bar along the bottom of the LCD indicates the progress. At 100% it indicates “ZEROING SENSOR” and another bar indicates the progress. Upon completion, the LCD indicates “ZERO HAS BEEN UPDATED” and the LCD returns to the “CAL” menu.

Procedure: Attach the cylinder flow regulator to the cylinder of 100% Nitrogen, open the valve fully and attach the brass fitting to the inlet fitting of the YESAIR.

Repeat this procedure for all installed sensors.

NOTE: If the user neglects to flow 100% Nitrogen over CO2 and O2 sensors or zero air over all other sensors, the instrument indicates an error.

Selecting the span procedure is the same as selecting the zero procedure. Simply use the **ARROW DOWN** button to scroll to “SPAN” then push the **MENU** button to select. From the “CAL” menu, use the **ARROW DOWN** button to scroll to the desired sensor then push the **MENU** button to select. The LCD indicates “SPAN” and the sensor selected and the gas value last used to span the selected sensor. Using the **ARROW UP** and/or **ARROW DOWN** button to set the value, one digit at a time. Next press the **MENU** button and the LCD indicates “SPAN” and “APPLY GAS NOW...” and the bar along the bottom of the LCD indicates the progress.

Note: Pressing the MENU button during the first stage of this procedure results in a cancelation of the span procedure.

SPAN:

YES Plus LGA 3 (THREE) POINT SPAN CALIBRATION PROCEDURE

YES Plus LGA provides 3 point span calibration for infrared CO2 and infrared CH4 percent volume range sensors **ONLY**, to provide the maximum accuracy. First complete the zero calibration. Next, the following steps guide you through the 3-point calibration procedure. For **ALL** other sensors, follow the single point calibration procedure indicate right after the 3-point calibration procedure.

Press the **MENU** button on the instrument to enter the main menu. Using the ARROW DOWN button scroll down to “CALIBRATE” and press the **MENU** button. The LCD will indicate “(CODE) ENTER SECURITY CODE”. The calibration function is security code protected to prevent unauthorized personnel or personnel that have not been trained, from performing this important function. Default Security code = 1234

Enter the security code correctly and the LCD indicates “CAL”. Using the ARROW DOWN button to scroll to “SPAN” and push the **MENU** button. The next menu indicates installed gas sensors.

6.0 CALIBRATION, CONT'D.....

CALIBRATION PROCEDURE, SPAN, CONT'D.....

The LCD indicates the list of installed sensors. Use the **ARROW DOWN** button to scroll to the CO2 sensor and press the **MENU** button again.

The LCD moves to the "**SPAN**" menu and indicates "**ENTER 1ST GAS VALUE**". The cursor flashes over the first of four digits indicating the user must set the correct 1st span gas value approximately 1000 ppm. This value must match the gas concentration on the cylinder of span gas for that specific sensor, and then press the **MENU** button.

YES Plus LGA 3 (THREE) POINT SPAN CALIBRATION PROCEDURE, CONT'D.....

The LCD indicates "**APPLY GAS NOW...**". A scroll bar at the bottom of the LCD indicates the progress on a scale of 0 to 100% as the instrument waits for sensor to stabilize to the span gas. Then the LCD indicates "**SPANNING CO2**". Once again the scroll bar at the bottom of the LCD indicates the span progress on a scale of 0 to 100%. Upon completion, the LCD indicates "**ENTER 2ND GAS VALUE**" and cursor flashes over the first of four digits indicating the user must set the correct 2nd span gas value approximately 2000 ppm. This value must match the gas concentration on the cylinder of span gas for that specific sensor, and then press the **MENU** button.

The LCD indicates "**APPLY GAS NOW...**". A scroll bar at the bottom of the LCD indicates the progress on a scale of 0 to 100% as the instrument waits for sensor to stabilize to the span gas. Then the LCD indicates "**SPANNING CO2**". Once again the scroll bar at the bottom of the LCD indicates the span progress on a scale of 0 to 100%. Upon completion, the LCD indicates "**ENTER 3RD GAS VALUE**" and cursor flashes over the first of four digits indicating the user must set the correct 3rd span gas value approximately 4000 ppm. This value must match the gas concentration on the cylinder of span gas for that specific sensor, and then press the **MENU** button.

The LCD indicates "**APPLY GAS NOW...**". A scroll bar at the bottom of the LCD indicates the progress on a scale of 0 to 100% as the instrument waits for sensor to stabilize to the span gas. Then the LCD indicates "**SPANNING CO2**". Once again the scroll bar at the bottom of the LCD indicates the span progress on a scale of 0 to 100%. Upon completion, the LCD indicates "**SPAN HAS BEEN UPDATED**"

NOTE: If for any reason user doesn't want all three points' calibration then it can be overridden by pressing & hold **ARROW UP** button till new screen will appears.

YES Plus LGA 1 (ONE) POINT SPAN CALIBRATION PROCEDURE

First complete the zero calibration procedure as indicated on page-28.

Next, press the **MENU** button on the instrument to enter the main menu. Using the **ARROW DOWN** button scroll down to "**CALIBRATE**" and press the **MENU** button. The LCD will indicate "**(CODE) ENTER SECURITY CODE**". The calibration function is security code protected to prevent unauthorized personnel or personnel that have not been trained, from performing this important function.

6.0 CALIBRATION, CONT'D.....

YES Plus LGA 1 (ONE) POINT SPAN CALIBRATION PROCEDURE, CONT'D.....

Enter the security code correctly and the LCD indicates "**CAL**". Using the **ARROW DOWN** button scroll to "**SPAN**" and push *the* **MENU** button. The next menu indicates installed gas sensors.

The LCD indicates the list of installed sensors. Use the **ARROW DOWN** button to scroll to the first sensor to be span adjusted and press the **MENU** button again.

The LCD moves to the "**SPAN**" menu and indicates "**SPAN GAS VALUE**". The cursor flashes over the first of four digits indicating the user must set the correct span gas value. This value must match the gas concentration on the cylinder of span gas for that specific sensor. Use the **ARROW UP**, **ARROW DOWN** and **MENU** button to set the span gas value then press the **MENU** button. If the span gas concentration is 50 (example) the value should read "050.0".

The LCD moves to the **SPAN** menu and indicates "**APPLY GAS NOW...**". A scroll bar at the bottom of the LCD indicates the progress on a scale of 0 to 100% as the instrument waits for sensor to stabilize to the span gas. Then the LCD indicates "**SPANNING CO**". Once again the scroll bar at the bottom of the LCD indicates the span progress on a scale of 0 to 100%. Upon completion, the LCD indicates "**SPAN HAS BEEN UPDATED**" and goes back to the "**CAL**" menu.

Repeat this procedure for all installed sensors.

NOTE-1: If the user neglects to flow 100% Nitrogen over CO2 and O2 sensors or zero air over all other sensors, the instrument indicates an error.

NOTE-2: The O2 sensor does not indicate the first span menu screen (**APPLY GAS NOW**). For this reason, ensure any Oxygen span gas utilized is connected and flowing to the sensor before entering the span menu. Alternatively, use the ambient environment as a source of 20.9% volume O2 but make sure you do not exhale in the direction of the pump inlet fitting. The CO2 you exhale will influence the value of the Oxygen reading. It is the only sensor that skips the first span calibration menu screen.

7.0 ADDING OR CHANGING PLUG-AND-PLAY SENSORS

The YES Plus LGA accommodates up to fifteen sensors. One of those sensors is temperature and is permanently installed in all instruments as a standard. Twelve of the sensor locations accommodate only gas sensors. Eight of the sensor locations accommodate only electrochemical toxic gas and/or Oxygen sensors. The other sensor locations can accommodate either the infrared CO2 sensor, the PID sensor or the catalytic combustible (flammable) gas sensor. See photo reference on page-16.

Although a RH (relative humidity) sensor is an option, it must be installed at the factory at the time of assembling the instrument and as such must be ordered at the time of ordering the instrument.

7.0 ADDING OR CHANGING PLUG-AND-PLAY SENSORS, CONT'D.....

SENSORS, CONT'D.....

All YES Plus LGA gas sensors are plug-and-play smart sensors. They can be added or changed at any time. The procedure to add or change a sensor is as follows:

1) Shut the instrument off. If the power adapter is plugged in, **UNPLUG IT BEFORE PROCEEDING. “WARNING” LEAVING AC ADAPTER PLUGGED IN WHILE CHANGING SENSORS CAN SERIOUSLY DAMAGE SENSORS. THIS DAMAGE WILL NOT BE COVERED UNDER WARRANTY.**

2) Rotate the swivel carrying handle to the front resting position. Turn the instrument over and loosen the four 1-1/2” long securing screws located on the bottom of the instrument. Turn the instrument right side up again and carefully remove the cover. The swivel handle is attached to the cover and will come off with it.

3) Gently slide the front panel with LCD display up and out of it's slot and stand it in front of the instrument. This ensures the display ribbon cable is out of the way for the sensor block removal. Remove the four securing screws retaining the sensor block and carefully lift it off, laying it to one side on top of the circuit board. If one or more sensors adhere to the sensor block while removing it, carefully remove them and plug them back into their locations. If they fall from the underside of the cover while removing it, they become damaged.

4) If you are removing a sensor, identify the one to be removed by the label on the side of the sensor then carefully grasp the sensor by the sides and pull upwards with a slight rocking motion to unplug it from the sensor sockets in the transmitter circuit board. **DO NOT DROP** the sensor (permanent damage could occur). The removed sensor should be stored in a clean, dry container with anti-static foam.

5) If another sensor is to be installed in it's place, ensure it is of the same “type” (electrochemical, infrared, PID/Catalytic), to be accommodated by the sensor location recently vacated. Carefully grasp the new sensor by the sides and line up all of the pins on the smart sensor board attached to the bottom of the sensor with the sockets on the transmitter board. Once the pins are all aligned, gently push the sensor down into the sockets in the transmitter circuit board. If it does not seem to be easy to insert the new sensor, **DO NOT FORCE** it. Double check the pin to socket alignment and try again.

NOTE: If no sensor is to be utilized in a specific sensor location, the opening must be filled with a sensor blanking plug to allow sampled air to reach all sensor locations.

6) Reattach the sensor block and tighten the securing screw until it will reach to the housing then do another three full turns (**DO NOT OVER TIGHTEN**). Carefully slide the front panel back into it's slot in the enclosure base. Carefully slide the cover into position ensuring that the front and rear plates align with the slots in the cover. Install the four 1-1/2” long securing screws and tighten. **DO NOT OVER TIGHTEN.**

7) Switch the instrument on and allow at least 20 to 30 minutes of warm up time before using.

7.0 ADDING OR CHANGING PLUG-AND-PLAY SENSORS, CONT'D.....

8) Once the sensor has been warmed / stabilized, perform a zero function using the pushbuttons on the front of the instrument. This function is part of the calibration procedure indicated on page-27. This can be performed in room air if you know the air in the environment is clean. If the sensor is CO₂ or O₂, 100% Nitrogen (N₂) must be flowed over the sensor as part of the zero function.

NOTE-1: If the newly installed sensor is not zero adjusted after installation, as outlined above, the display may indicate a slight reading of the target gas even in a clean environment.

NOTE-2: *For best accuracy*, all sensors should be zero adjusted and bump tested after being installed.

Sensor Locations:

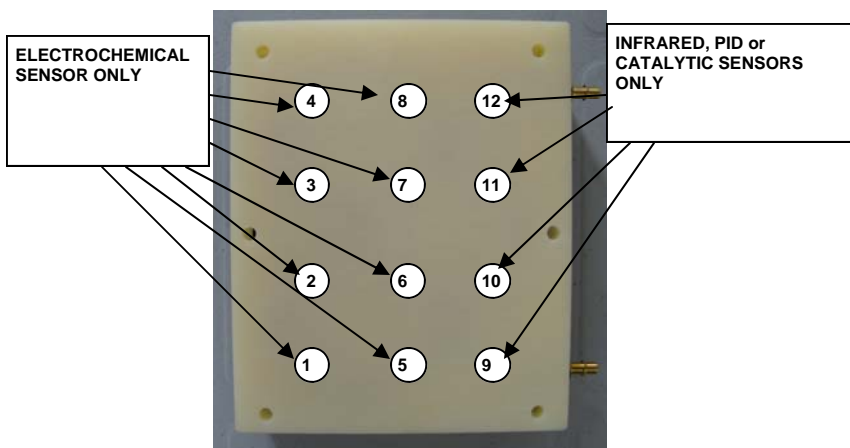

Sensor locations 1 to 8 accommodate the 3-electrode style electrochemical sensors. Locations 5 and 6 will also accommodate electrochemical sensors that require a bias voltage. Locations 7 and 8 will accommodate the typical 3-electrode sensor, and also 2-electrode style electrochemical sensors. (This is typically an oxygen sensor, but some rare gases also fall into this category.)

Positions 9 through 12 accommodate the 3-pin infrared (IR), catalytic or PID sensors. These sensors have a higher power draw and as a result, the pins have been spaced differently to ensure they are not accidentally placed in locations 1 to 8. Doing so could potentially damage the electronics of the instrument.

8.0 INFORMATION RECORDING (DATA LOGGING) OPERATION

Refer to the software manual for complete details on loading and using the YES Viewer software.

9.0 MAINTENANCE

Externally, the YES Plus LGA requires only cleaning with a damp cloth, wiping off the exterior surface and basic inspection for obvious damage or problems. Internally, sensors should be maintained because they have a specific life span. As they age, they must be calibrated (null and span adjusted) for accuracy. If one or more sensors do not respond to span gas, check the age of the sensor as they may have expired. Refer to the sensor replacement and calibration sections of this manual for more details. Contact the factory for service to replace expired sensors or any other parts that are required.

10.0 ACCESSORIES

1) Hand-held probe.

Supplied with 30" of hose and allows the user to attach a sample probe (wand) to reach into hard to get at areas for sampling.

NOTE: Remote sampling is for gases only. Temperature and RH sensors are mounted on rear panel of instrument.



2) Hard shell, foam-lined, carrying / transport case

